



YE4 系列三相异步电动机  
YE4 Three Phase Induction Motor

# 使用说明书

## Operation Manual

安徽皖南电机股份有限公司  
Anhui Wannan Electric Machine Co.,Ltd

衷心感谢您选购、使用皖南电机。

在使用电动机之前，请扫码仔细阅读本说明书，以便您正确的使用和维护。

## 一、产品概述

我公司生产的 YE4 系列三相异步电动机，是在 YE3 系列高效电动机基础上，采用新技术、新工艺、新材料进行优化设计生产的新型高效率节能电动机。该系列效率符合 GB18613-2020（2 级能效）。

电压	380V
功率范围	0.37 ~ 375kw
防护等级	IP55
绝缘等级	F 级
冷却方式	IC411
备注：本说明书也适用于在本系列基础上由电气、结构派生的相关系列产品，如异电压、异频率，防护等级（IP56/IP65）等相关产品。	

### 电动机型号的意义：

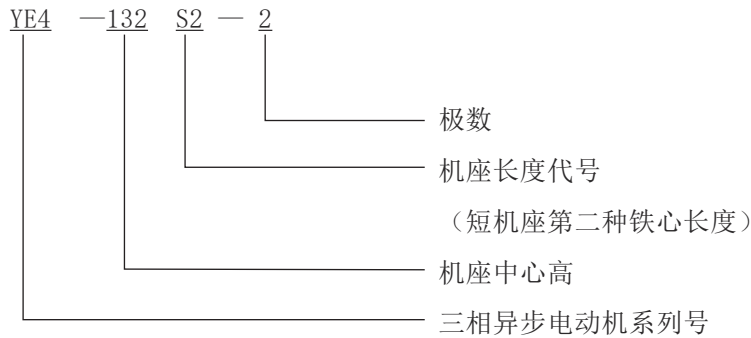

## 二、运行使用条件

- 2.1 海拔不超过 1000m。
- 2.2 环境空气温度随季节而变化，但最高不超过 40℃，最低为 -15℃。
- 2.3 电动机不得用于含有易燃性气体、化学腐蚀性气体或其它有害气体的环境中（特殊环境用电动机除外）。
- 2.4 高原环境、高温、低温与特殊环境用电动机需特殊定制。

## 三、搬运与贮存

- 3.1 搬运电动机时，一定要使用所提供的吊攀，在搬运前，确保吊攀安装正确且牢固。
- 3.2 电动机升降时应避免摇摆和振动，以防损坏轴承和其它元件。
- 3.3 建议电动机都存储在干燥无尘的环境中；如果电机安装或者存储于户外，需要增加相应的防护装置，以免电机性能因长期暴晒、雨水侵蚀、冰雪或者尘土而受到影响。
- 3.4 对于驱动端和非驱动端采用封闭轴承的电动机，应在其出厂存储 1 年后检查轴承；储存 2 年

或超过 2 年，建议更换轴承；对于带有再润滑装置的电动机，若电机出厂后存储 2 年或超过 2 年，建议更换润滑油脂。

3.5 对于存储半年的电动机，建议每 2 个月将电机轴旋转 180 度；存储超过半年的，通电运转一段时间，使轴承润滑脂分布均匀。

## 四、调试



**警示：**所有工作都必须由熟练工人进行操作。电机做任何操作之前，确保电机与主线及辅助电源断开。并且，确保电源不被意外开启。

### 4.1. 准备工作

4.1.1 仔细检查电动机外观是否完好、核对电动机铭牌内容是否与实际需求相符，有无受潮现象。

4.1.2 检查电机在运输过程中有无变形和损坏，紧固件有无松动或脱落。

4.1.3 轻轻转动电动机转轴，转动应无异响。

### 注意

检查过程中，若有疑问，请向有关专业技术人员请教或与我们联系。

### 4.2 安装

4.2.1 对带底脚的电动机，安装基础可以是金属平台，也可以是混凝土结构平台，无论是何种基础都应该平整、坚固，且有足够的强度和硬度支撑电机。

4.2.2 电动机安装完毕后必须将吊环拧紧。

4.2.3 当电机竖直安装且电机轴驱动端向下时，建议在非驱动端增加防护措施，以免水及其它外部物体进入风扇罩而影响电机散热；当电机竖直安装且驱动端轴朝上安装，建议采取必要的防护措施，防止液体沿电机轴进入电动机内。

### 4.3 电气连接

4.3.1 电机接线方式通常有两种，如未做特殊说明，3kW 及以下电机为 Y 接法，3kW 以上为  $\Delta$  接法，正确的连接片位置如图所示。

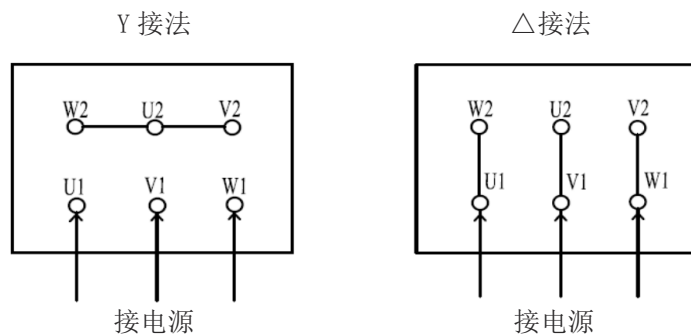

4.3.2 YE4 系列电机接线盒内有接地端子，确保其可靠接地。

4.3.3 电动机的相序 U、V、W 须与接入外电源相序 A、B、C 一一相对应，电动机转向从轴伸端视

之为顺时针方向，用户如需反转，对调 A、B、C 的任意两相的电源接入顺序即可。

4.3.4 电源频率与额定频率偏差不超过 2%，电源电压与额定电压偏差不超过 5%。

4.3.5 引入的电缆芯线要接在两垫圈之间，注意芯线的飞刺不要突出。引入接线孔时应防止线芯损伤，引入电缆还须用接线压板和弓形垫圈压紧固定，防止窜动。

4.3.6 安装时，应将防水螺套的密封膜彻底清除，以确保防水螺套和电缆间的密封性。

清除前



清除后



4.3.7 安装接线盒时必须将螺孔位置调整至朝向地面（尤其是户外电机，否则要在接线盒上方安装防护措施）

4.3.8 YE4 系列电动机可以根据客户要求加装 PTC、PT100、热敏电阻开关和防潮加热带及其它相关配件；YE4 系列电动机也可以根据客户要求加装排水孔。

#### 4.4 电机与负载的联接

4.4.1 电动机允许采用弹性联轴器、正齿轮及皮带轮与负载机械联接。

4.4.2 采用联轴器联接时，电动机轴中心线与负载机械的轴中心要重合，以免电机在运行中产生强烈振动。

4.4.3 电动机与设备安装连接后，起吊不能使用吊环，否则会直接损坏电机。

## 五、启动

### 5.1 准备工作

5.1.1 检查三相电源电压是否正常。

5.1.2 新安装或停用三个月以上的电动机起动前应测量相位间绝缘电阻，用 500V 兆欧表测量电动机定子绕组绝缘电阻，所测值在冷状态下应不低于 5 MΩ，否则要进行干燥处理。



**警示：**测试前应拆去电动机接线片，测量后绕组要立即放电，切勿直接触摸。

5.1.3 检查电动机的紧固螺栓是否拧紧，轴承是否有充足的润滑油脂。

5.1.4 检查联轴器螺钉和销钉是否紧固，皮带联轴是否良好，紧松是否合适，机组转动是否灵活，有无卡位、窜动或异响。

5.1.5 检查电动机的接线（包括电动机热保护电阻和防潮加热带等配件的接线）是否符合要求，电机是否可靠接地。

5.1.6 检查电动机的冷却风扇，确保其没有被卡住。

## 5.2 启动注意事项

5.2.1 电动机允许满压、降压启动或软启动。但应注意，满压启动电流为额定电流的 4.5 ~ 8.0 倍。降压启动时，因转矩与电压的平方成正比，电压下降时启动转矩也随之降低。故当静负荷相当大时只能采用满压启动。

5.2.2 电动机接好线，经检查确认无误后，方可接通电源进行空载试运转，空载试运行时间一般在 20 ~ 30 分钟，并观察电机有无异常现象，待空转正常后方投入负载运行。

**（注：电机连续空载启动不得超过 3 次）**

5.2.3 合闸后，如果电动机不转，应立即切断电源，以免烧毁电机。

5.2.4 严禁反复多次启动，以免电动机过热，甚至烧毁电机（特别是连续带负载直接启动）。

## 5.3 运行时的注意事项

5.3.1 严禁缺相运行。

5.3.2 防止过载，过载会导致过电流过热，过热将缩短绝缘寿命，降低电动机的可靠性。

5.3.3 电源电压的波动不得超出额定电压的 95% ~ 105%。

5.3.4 通电前应取下轴伸上的轴套和平键，使身体、衣物远离电动机旋转部分。

5.3.5 电机运行时若有异常应立即停机。

5.3.6 电机在运行过程中，表面应保持清洁，进风口不得受尘土纤维阻碍。

5.3.7 电动机若安装了防潮加热带，加热带切勿在电机运行时加热。

# 六 电机的维护

6.1 电机的进风口及风道需保持清洁畅通，定期对电机进行检查和清扫，外壳不得堆积灰尘，不得用水喷射清扫电机。

## 6.2 轴承和润滑油脂的检查及更换

6.2.1 电动机运行时轴承允许温度不得超过 95 °C（温度计法）。

6.2.2 轴承每运行 2500 小时（约半年）需至少检查一次，如发现轴承润滑脂变质必须及时更换（封闭式轴承在使用寿命期限内不必更换润滑脂）。更换前，须将轴承内外盖、贮油腔内的废油以及排油装置的油管、油杯内的废油清理干净，并将轴承清洗干净。

6.2.3 润滑脂推荐采用 2 号中小型电机轴承润滑脂。轴承润滑油使用量和加油时间见附表 1，机座号和适用轴承型号见附表 2。

6.3 对于没有轴承内、外盖（如 H80 ~ 132）的电机，拆卸时，应先拆下风罩、再拆掉轴伸端的 V 型轴封环，拆去前端盖、后端盖的固定螺栓，可将后端盖连同转子、风扇连体抽出。轴承的拆卸应借用专用工具进行操作。

6.4 电机受潮后，必须经干燥处理后方可使用，干燥处理可采用烘干或短路电流法。如采用烘干法，温度应逐渐升高，但不可超过 145 °C；若采用短路电流法，电机处于短路状态，其输入电流以 0.6 ~ 0.8 倍额定电流值为宜（注：严重受潮的电机不宜用此方法，以免对匝间、对地造成损坏）。

6.5 更换绕组时，须记下原绕组的形式、尺寸、线规、匝数。随意改变设计绕组参数会使电动机

某项或几项性能恶化，以致不能使用。

6.6 零部件维修、更换，须由专业技术人员按有关技术标准进行维修、验收。

6.7 为保证电动机的正常运行，应根据实际使用情况对电动机进行定期检查，并需每年检修一次。

6.8 电动机存放过久，可能会导致油脂硬化，在刚启动时会有异响。需空载运行半小时以上，使润滑油脂均匀分布。

## 七、运行中的故障及其主要原因

在运行中必须经常检查电动机，以便能及时发现各种故障而消除之，不然这些故障可能引起事故。下面叙述的是最常见到的故障以及原因：

### 7.1 机械故障

7.1.1 轴承过热：①可能是由于油量不足，油不清洁，油的品质低，水滴侵入，油环卡住，转轴或轴衬表面的故障，转轴颈与轴衬间的间隙缩小，轴承歪斜，轴颈压力过度及产生轴电流等所引起；②滚珠及滚柱轴承过热，可能是由于润滑油不足或过多，转轴弯斜，转轴磨擦过大，润滑油内有杂质及外来物品以及钢珠损坏等所引起。

7.1.2 漏油及机内积油：可能是由于①轴承内油量过多，轴承所有油质不良或粘度不对等所引起；②轴承油槽内压力和轴承盖下压力不均匀所致。

7.1.3 电动机振动异常：可能是①机组的轴线没有对准，电动机在底板上的位置不正，底板不均匀的下沉，底板钢度不够，底板的振动周期与电动机（机组）的振动周期一样或接近；②转轴弯曲或轴颈振动，联轴器配合不良，转子皮带盘及联轴器平衡不良，轴颈与轴衬间的间隙过大，皮带轮粗糙或皮带轮装置不正，传动机构工作不良及有碰撞现象；③鼠笼转子断裂，转子铁心振动等。

7.1.4 转子偏心：可能是由于轴衬松掉、轴承位移，转子及定子铁心变形，转轴弯曲及转子平衡不良等所引起的。

### 7.2 电气故障：

7.2.1 启动异常：①可能由于接线错误、线路断路；②工作电压不对、负载力矩过高或静力矩过大和启动设备有故障等所引起。

7.2.2 电机过热：可能由于线路电压高于和低于额定值、过负荷、冷却空气量不足、电机环境温度过高、匝间短路及电动机不清洁等所引起。

7.2.3 绝缘损坏：可能由于①工作电压过高；②酸性、碱性、氯气等有腐蚀性气体的损坏；③运动异常导致线圈发热；④使用环境温度过高或者机械碰伤、温度过高，在温度小于 0℃ 及以下保存和水分侵入等所引起。

7.2.4 绝缘电阻：可能由于不清洁、湿度太大，因温度变化过甚，以致表面凝集水滴，绝缘磨损和老化等所引起。

附表 1:

轴承润滑油使用量和加油时间

机座号	极 数	油脂量 (g)	加油时间 (h)
180	2	20	4200
	4	20	7000
	6, 8	20	9000
200	2	25	3100
	4	25	6500
	6, 8	25	8500
225	2	25	3100
	4	30	6200
	6, 8	30	6200
250	2	30	2600
	4	35	6000
	6, 8	35	8000
280	2	35	2000
	4	40	5500
	6, 8	40	7500
315	2	30	2500
	4, 6, 8, 10	36	2500
355	2	36	2500
	4	47	2500
	6, 8, 10	47	2500

附表 2:

机座号和适用轴承型号表

机座号	极 数	轴伸端	非轴伸端
80	2, 4, 6, 8	6204-2RZ	6204-2RZ
90	2, 4, 6, 8	6205-2RZ	6205-2RZ
100	2, 4, 6, 8	6206-2RZ	6206-2RZ
112	2, 4, 6, 8	6206-2RZ	6206-2RZ
132	2, 4, 6, 8	6208-2RZ	6208-2RZ
160	2, 4, 6, 8	6309-2RZ	6309-2RZ
180	2, 4, 6, 8	6311-2RZ	6311-2RZ
200	2, 4, 6, 8	6312-2RZ	6312-2RZ
225	2, 4, 6, 8	6313-2RZ	6312-2RZ
250	2	6313	6313
	4, 6, 8	6314	6313
280	2	6314	6314
	4, 6, 8	6317	6314
315	2	6317	6317
	4, 6, 8, 10	NU319	6319
355	2	6319	6319
	4, 6, 8, 10	NU322	6322

注: 电机用轴承型号以实物使用型号为准, 如有变动, 恕不另行通知。

注: 由本系列电机所派生出的高原、高环温、TH(三防)、W(户外)等相关电机启动、调试、维护相关内容也可参考本说明书。

We are truly grateful for your purchasing of Wannan Motors. Before using the motor, please scan the QR code to read the manual so as to use and maintain the motor in a right way.

## 1. Summary

YE4 Series Three Phase Induction Motor is designed on the basis of YE3 series motors, and manufactured according to the level 2 energy efficiency standard of China national motor standard GB18613-2020.

Voltage	380V
Rating Power	0.37 ~ 375kw
Protection	IP55
Insulation	F
Cooling	IC411
Tips: The operation of its derivative products on the basis of its data or structure (including non-standard voltage、 non-standard frequency and IP56/IP65 motors) please refer to the manual.	

### Model instruction:

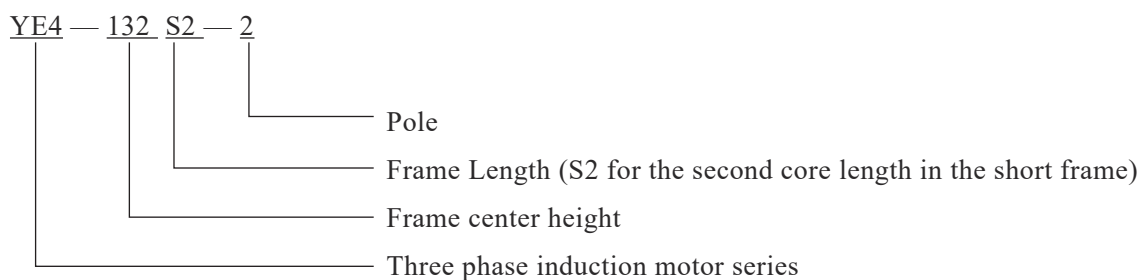

## 2. Usage

2.1 The altitude exceeds not 1000m above sea level.

2.2 The ambient temperature is neither higher than 40°C nor lower than -15°C although it is always changing with season.

2.3 The motor cannot be applied in the circumstance where contains inflammable gases, chemical corrosive gases and other harmful gases or steam (Except for the special-purpose motor).

2.4 Highland、 high/low temperature environment motor should be customized.

## 3. Handling and storage

3.1 Lift motor with the eyebolt offered (ensure the eyebolt is tightened in advance).

3.2 Care must be taken during lifting and lowering to avoid any falling, bumping, shock or vibration which will damage bearing and other elements.

3.3 It is recommended that the motor be stored in dry and clean environment; a protective cover or shield is needed to protect it from the insolation, rain, snow and dust when the motor is installed or stored outdoors.

3.4 If the DE and NDE bearings are of sealed type, it is recommended that the bearing be checked if the motor has been stored for 1 year, replaced if stored for 2 or more years; if the bearings are of



regrease type, replace its grease if it has been stored for 2 or more years.

3.5 Turn the shaft by 180° with hand every 2 month for the motor which has been stored half year; the motor need to work for a period of time to make the lubrication grease equidistribution when the motor has been stored longer than half year.

## 4. Test



**Warning:** Installation and debugging should be performed by technician. Cut off the electricity of the main and auxiliary power supply before any work and ensure that all power supply will not be connected.

### 4.1 Preparation work

4.1.1 Check and ensure the appearance of the motor is in good order. Check and ensure that the motor nameplate is consistent with the actual requirement.

4.1.2 Ensure that the elements have been connected correctly, and the fasteners are tight.

4.1.3 Rotate the motor shaft gently to see whether its rotation flexible and quick or not.

**Note** Any problems please consult the technician or contact us.

### 4.2 Installation

4.2.1 For the motor with feet, the foundation of installation can be a metal base or concrete structure platform, whatever the foundation is made of ensure that it has enough strength and rigidity against motor.

4.2.2 Screw the eyebolt when the installation has finished.

4.2.3 If the motor is installed vertically with its DE shaft downwards, a protective canopy is recommended to cover the fan cowling since it can prevent the ingress of water and foreign objects that may affect the motor's cooling; if the motor is installed vertically with DE shaft upwards, necessary protective measure is recommended to be taken to prevent the liquids from entering the motor windings via the shaft.

### 4.3 Electrical connection

4.3.1 There are Y and  $\Delta$  two connection, in general the motor of and below 3kW is of Y connection, above 3kW is of  $\Delta$  connection. **Ensure that all terminals are connected as the following diagram:**

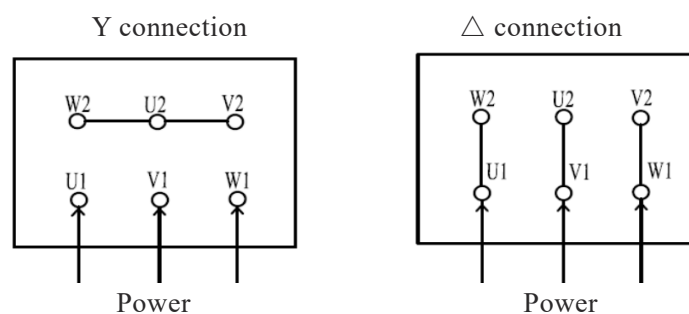

4.3.2 Ensure that there is one terminal in the connection box being grounded.

4.3.3 Motor will rotate clockwise viewed from driving shaft end if the terminal U,V,W is connected respectively to power line A, B, C. Otherwise the motor will rotate anticlockwise. Provided the reverse rotation is need, interchange any two of the three terminal U, V, W.

4.3.4 Frequency deviation between power supply and rated value is  $\pm 2\%$ , voltage deviation is  $\pm 5\%$ .

4.3.5 Put the core of the lead-in electric cable between two gaskets, and ensure no spur on the cable. Be careful when draw the cable through cable entry at the terminal box, and fix the cable with a blanking plate and bow washer.

4.3.6 The membrane must be completely removed so as to guarantee the sealing between the gland and electric cable. DETAILS SEE PICTURE BELOW:



4.3.7 Set the screw hole facing ground when mounting the terminal box (especially outdoor motor, otherwise a protective canopy must be covered on the connecting box)

4.3.8 YE4 series motor can also be customized as the structure that contains PTC、PT100、thermal resistor switch and other related accessories; as well as the condensation drain hole.

#### **4.4 Coupling**

4.4.1 Coupling, gear and belt pulley are allowed to be used for transmission.

4.4.2 The shaft center of the motor must keep consisting with that of the driven equipment in the same level.

4.4.3 Eyebolt is not available when lifting the motor which has been connected to driven equipment.

### **5.Start**

#### **5.1 Preparation**

5.1.1 Check three phase power supply

5.1.2 For newly installed motor and the motor having been standstill for more than 3 months, it is recommended to measure the inter-phase insulation resistance of the winding with 500v megohmmeter, the value should be no less than 5 M $\Omega$ . Otherwise the motor must be dried.



**Warning:** Before measurement remove the terminal plate; and discharge electric immediately after measurement . Do not touch directly by hand.

5.1.3 Check the fasteners to see whether they are tight or not, and whether the lubrication grease adequate or not.

5.1.4 Ensure that all screw and plug of coupling are tightened; pulley works well with its belt being elastic; assembling is flexible without abnormal sounds.

5.1.5 Ensure that all cables (including ones on motor protection resistance and space heater) have been correctly connected, and the motor has been safely grounded.

5.1.6 Ensure that the cooling fan will not be locked during motor operation.

## 5.2 Start matters

5.2.1 Motor can be started at rated voltage and reduced voltage, or adopt soft start. If the motor starts with rated voltage its starting current is 4.5-8.0 times rated value. As torque is proportional to voltage square, the torque will be reduced when the motor is started at reduced voltage. So if the static load is fairly large, the motor can be only started with rated voltage.

5.2.2 After checking all the connections, turn on power for no-load operation test for 20-30min, and then put into with-load operation if it runs smoothly in operation test (Tips: Continuous with-load operation should be no more than 3 times).

5.2.3 Cut off electricity supply immediately if the motor cannot work when switch on.

5.2.4 Do not start the motor continuously in case the motor overheat or even burning (especially continuous with-load direct start).

## 5.3 Operation matters

5.3.1 Non-full phase operation is prohibited.

5.3.2 Avoid overload, since current overheat which is caused by overload will shorten the insulation lifetime, reduce the motor's reliability.

5.3.3 Voltage fluctuation of the supplied power cannot exceed 95% ~ 105% of the rated voltage.

5.3.4 Remove the sleeve and key on the shaft end before power on, keep body and clothes far away from rotating parts of motor.

5.3.5 Stop the motor immediately if any abnormal sound occurs.

5.3.6 Keep the motor clean and in good ventilation during operation.

5.3.7 Space heater (if the motor has) cannot be working when the motor is running.

## 6. Maintenance

6.1 Check and clean the motor periodically, ensure that no dust cover on the motor. Do not clean the motor with water spray.

6.2 Bearing and grease

6.2.1 Bearing temperature should not exceed 95°C (Thermometer method) during operation.

6.2.2 The bearing should be inspected every 2500h (about half a year) operation. The bearing grease should be replaced immediately if the grease is found to be spoiled (Sealed bearing need not replace its lubrication grease in its lifetime). But the waste grease in bearing internal/external cover, oil chamber, oil tube, oil nipple must be cleaned out.

6.2.3 No.2 lubricating grease for small medium size motor is recommended. Re-grease duration and grease mass see attachment 1, bearing size see attachment 2.

6.3 Disassemble the motor (motor of H80~132 without bearing internal/external cover) as the following order: firstly remove fan cover, and V-seal ring on the drive end, secondly remove the bolts on front end cover and rear end cover, and lastly take out the rotor together with the front end cover and cooling fan.

6.4 Motor must be dried before use if it has been affected with damp by means of drying in the oven or short-circuit current. The temperature should be increased gradually but not exceed 145°C when dried in the oven. And when the motor dried by short-circuit method, it should be connected as short circuit whose input current is 0.6-0.8 time rated current. However the short-circuit method is not suitable for the motor which is heavily damped, since it may damage winding's performance.

6.5 If the winding needs to be replaced, the original winding's type, dimensions, diameter and turns of coil should be recorded. Arbitrarily changing of winding will decrease the performance of the motor, and even to damage the motor.

6.6 Maintenance or replacement of its components must be done by professional worker.

6.7 The motor need to be periodically inspected according to its actual operation, overhaul at least once a year.

6.8 Grease may harden in long-time idling. When abnormal sounds occur at the beginning of operation, the motor need to be operated without load for half an hour so as to soften grease and restore its function.

## **7. Failures & causes**

Check motors frequently in order to remove the possible failure in advance. The common failures are as follows:

### **7.1 Mechanical fault:**

7.1.1 Bearing overheat: lack of grease, dirty grease, low quality grease, water intrusion, oil ring stuck, surface fault of bushing, narrow distance between shaft and bushings, excessive pressure on shaft neck and axis current and so on.

7.1.2 Leakage of grease: too much grease in bearing, grease of bad quality or incorrect viscosity, any unbalanced pressure between bearing oil container and the bearing cover.

7.1.3 Strong vibration: inconsistent center line of the shaft between motor and the driven machine, incorrect mounting position on base plate, shaft bending, bad cooperation of coupling, unbalance of pulley or coupling, large space between shaft journal and bushing, broken rotor bar, vibration of stator core, uneven surface of base plate, inadequate rigidity of base plate, similar or same vibration

cycle of the motor and the base plate, rough belt coupling, incorrect position of the belt coupling, poor operation of the transmission or the collision of the motor, etc.

7.1.4 Eccentric of rotor: loose bushing, bearing displacement, the deformation of rotor and stator, bend of the shaft and poor balance of the rotor.

## **7.2 Electrical Fault:**

7.2.1 Abnormal starting: incorrect connection, open circuit, incorrect voltage, too high load torque and too high static torque, starting device failure and so on.

7.2.2 Motor overheating: too high or too low voltage, overload, lack of cooling air, too high ambient temperature, short circuit or dirty of the motor, etc.

7.2.3 Insulation damage: acidic, alkaline, chlorine, and other corrosive gases, winding overheat, mechanical damage, too high environment temperature, storage below 0°C or motor being dampened, etc.

7.2.4 Low insulation resistance: uncleanness, high humidity, sharp temperature change, condensation on the surface, damage or aging of insulation material, etc.

Attachment 1:

### Lubrication Grease Content and Lifespan

Frame	P	Grease content (g)	Re-lubrication interval (h)
180	2	20	4200
	4	20	7000
	6	20	9000
200	2	25	3100
	4	25	6500
	6	25	8500
225	2	25	3100
	4	30	6200
	6	30	6200
250	2	30	2600
	4	35	6000
	6	35	8000
280	2	35	2000
	4	40	5500
	6	40	7500
315	2	30	2500
	4-10	36	2500
355	2	36	2500
	4	47	2500
	6-12	47	2500

Attachment:

### Frame and bearing size

Frame	Poles	DE	NDE
80	2,4,6,8	6204-2RZ	6204-2RZ
90	2,4,6,8	6205-2RZ	6205-2RZ
100	2,4,6,8	6206-2RZ	6206-2RZ
112	2,4,6,8	6206-2RZ	6206-2RZ
132	2,4,6,8	6208-2RZ	6208-2RZ
160	2,4,6,8	6309-2RZ	6309-2RZ
180	2,4,6,8	6311-2RZ	6311-2RZ
200	2,4,6,8	6312-2RZ	6312-2RZ
225	2,4,6,8	6313-2RZ	6312-2RZ
250	2	6313	6313
	4,6,8	6314	6313
280	2	6314	6314
	4,6,8	6317	6314
315	2	6317	6317
	4, 6,8,10	NU319	6319
355	2	6319	6319
	4, 6,8,10	NU322	6322

Note: Information here is indicative only. Actual product may differ.

Note: Special types derived from this series motors like -G, high ambient temperature, -Th, -W refers to part of this manual regarding modulation, start, maintenance matters.

## 敬告用户：

请您按照本使用说明书的规定，正确地使用和储存电动机，我们将为您提供优质、快捷的服务。

在电动机使用过程中，您如有什么疑惑请与我们联系，我们将及时给予您满意的解答；您有什么良好的建议请向我们提出，以便我们改进，为您提供优质、快捷的服务。

安徽皖南电机股份有限公司对本使用说明书保留最终解释权。

请勿在未事先获得安徽皖南电机股份有限公司书面许可的情况下向第三方复制、公布或者使用本使用说明书内容。

## Dear user,

Please use and store the motor right following the instruction of the manual. We will make our effort to provide you with high-quality and prompt service. Contact us if you had any questions in application, and we will offer you timely and effective resolution; let us know if you had any advices or suggestions, with which we can improve ourselves and make service better. Anhui Wannan Motor Co., Ltd. reserves the right of final interpretation of the user manual. No copy, disclosing or using of the content of this user manual to third parties prior to written permission from Anhui Wannan Motor Co., Ltd.

## 安徽皖南电机股份有限公司

Anhui Wannan Electric Machine Co.,Ltd

地址：安徽省泾县泾川镇南华路 86 号

**Address:** No.86 Nanhua Road Jingxian County Anhui Province P.R.C

销售处 **Sales department:** 400-111-0563      0563-5031908 5031988

客户服务中心 **Customer service center:** 0563-5031953

企业管理处 **Enterprises management department:** 0563-5031954

质量检验处 **Quality inspection department:** 0563-5031910 5031985

传真 **Fax:** (0563) 5029999 5023698

网址 **Website:** <http://www.wnmotor.com>

E-mail: [wndjc@wnmotor.com](mailto:wndjc@wnmotor.com)

邮编 **Postal code:** 242500

---

本说明书内容如有变动，恕不另行通知。

**Content in the manual may be changed without prior notice.**