



YE4L 系列
铝机壳三相异步电动机

YE4L SERIES ALUMINUM CASING
THREE PHASE ASYNCHRONOUS MOTOR

使用说明书
Operation Manual

安徽皖南电机股份有限公司
Anhui Wannan Electric Machine Co.,Ltd

衷心感谢您选购、使用皖南电机。

在使用电动机之前，请扫码仔细阅读本说明书，以便您正确的使用和维护。

我公司生产的 YE4L 铝机壳三相异步电动机，采用新技术、新工艺、新材料进行优化设计生产的新型高效节能一般用途电动机，铝机壳，轻质美观，效率符合国家电动机能效标准 GB18613-2020 中规定的 2 级能效规定，适用于长期运行的场合，能大量节能。

电动机型号的意义：

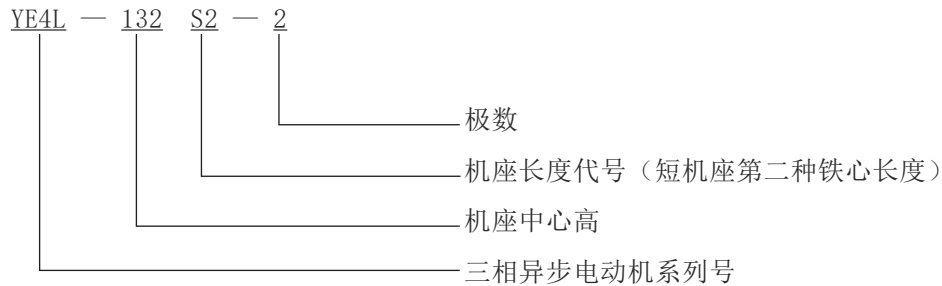

一、运行使用条件

1. 海拔不超过 1000m。
2. 环境空气温度随季节而变化，但最高不超过 40℃，最低为 -15℃。
3. 最湿月月平均最高相对湿度为 90%，同时该月月平均最低温度不高于 25℃。
4. 电动机允许满压或降压起动，但应注意，满压起动电流为额定电流的 3.3 ~ 8.0 倍。降压起动时，因转矩与电压的平方成正比，电压下降时转矩也随之降低。故当静负荷相当大时只能用满压起动。
5. 电动机不得用于含有易燃性气体、化学腐蚀性气体或其它有害气体的环境中（特殊环境用电机除外）。
6. 电动机必须保持清洁，进风口及风道必须畅通无阻。
7. 电机接线通常有两种方式，未做特殊说明，4kW 以下电机为 Y 接法，4kW 及以上为 Δ 接法，使用前检查出线端在出线盒内的连接片位置是否正确，正确的连接片位置如图 1 所示。



图 1 有六个出线头的低压定子出线接法示意图

二、安装与使用

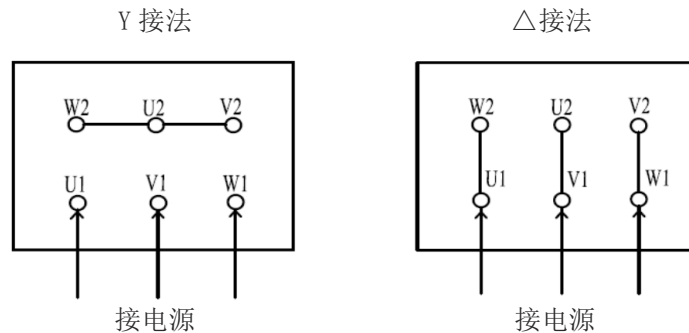

警告!

搬运电动机时，一定要小心谨慎！
强烈的摔、碰、震会严重损坏轴承及其他元件。
吊装带有吊攀的电动机时，一定要将吊攀旋紧

1. 安装前的检查

- 仔细检查电动机外观是否完好、核对电动机铭牌内容是否与实际需求相符。
- 轻轻转动电机转轴，转动应轻快、灵活。
- 检查各零部件应联接正确、装配良好，紧固件应无松动。
- 打开接线盒盖，用 500V 兆欧表测量电动机定子绕组绝缘电阻，所测值应不低于 5 MΩ。

注意：检查过程中，您若有疑问，请向有关专业技术人员请教或与我们联系。

2. 安装



警告!

1. 电源电压的波动不得超出额定电压的 95% ~ 105%。
2. 严格按图接线。
3. 必须接好接地线。
4. 通电前应取下轴伸上的轴套和平键，保持身体、衣物远离电动机旋转部分。
5. 电机运行若有异常立即停机。

- 电动机的安装应由专业技术人员完成。
- 电动机允许采用弹性联轴器、正齿轮及皮带轮传动。
- 电动机轴中心与被传动的主机轴中心要保持一致。
- 对带底脚的电动机，安装平面应平整、坚固。
- 联接电动机的电源线（电缆）不宜过细、过长。
- 引入的电缆芯线要接在两垫圈之间，注意芯线的飞刺不要突出。
- 引入接线孔时应防止线芯损伤，引入电缆还须用接线压板和弓形垫圈压紧固定，防止窜动。
- 六端子接线盒通过连接片改变接法，可适应两种不同电压需要（见接线盒盖内侧）
- 电动机的相序 U、V、W 须与接入外电源相序 A、B、C 相对应，电动机转向从轴伸端视之为顺时针方向，否则电动机将反转，用户如需反转，可对调 U、V、W 的任两相。
- 电动机内、外接地螺栓必须可靠接地。

电动机接好线，经检查确认无误后，方可接通电源进行空载试运转，空载运行足够长的时间（一般在 30 ~ 40 分钟），并观察电机有无异常现象，待空转正常后投入负载运行。

三、维护与维修



警告!

1. 严禁缺相运行。
2. 反复多次起动会导致电机过热，甚至烧毁电机（特别是连续带负载直接起动）。
3. 防止过载，过载会导致过热，过热将缩短绝缘寿命，降低电动机的可靠性。

1. 电动机应定期检查和清扫，外壳不得堆积灰尘，不得用水喷射清扫电机。

2. 电动机运行时轴承允许温度不得超过 95℃（温度计法）。轴承每运行 2500 小时（约半年）至少检查一次。如发现轴承润滑脂变质必须及时更换。更换前，须将轴承外盖、贮油盒内的废油以及排油装置的油管、油杯清理干净，并将轴承清洗干净。润滑脂推荐采用 2 号中小型电机轴承润滑脂。轴承润滑油使用量和加油时间见附表 1，机座号和适用轴承型号见附表 2。

3. 对于存储半年的电动机，建议每 2 个月将电机轴旋转 180 度；存储超过半年的，通电运转一段时间，使轴承润滑脂分布均匀。

4. H63 ~ 132 机座号的电机没有轴承内、外盖。拆卸电动机时，应先拆下风罩、再拆掉轴伸端的 V 型轴封环，拆去前端盖、后端盖的固定螺栓，将后端盖连同转子、风扇连体抽出。

5. 电机受潮后，必须经干燥处理后方可使用。干燥处理可采用烘干或短路电流法。在烘培过程中，温度应逐渐升高，但不可超过 145℃。用短路电流法干燥时（严重受潮的电机不宜用此方法，以免发生电解现象。），电机处于短路状态，其输入电流取 0.6 ~ 0.8 倍额定电流值为宜。

6. 更换绕组时，须记下原绕组的型式、尺寸、线规、匝数。随意改变设计绕组会使电动机某项或几项性能恶化，以致不能使用。

7. 零部件维修、更换，须由专业技术人员按有关技术标准进行维修、验收。

8. 为保证电动机的正常运行，应根据实际使用情况对电动机进行定期检查，并需每年检修一次

四、运行中的故障及其主要原因

在运行中必须经常检查电动机，以便能及时发现各种故障而消除之。不然这些故障能引起事故。下面叙述最常见到的故障和原因：

1. 机械的故障

• 轴承过热：可能是由于油量不足，油不清洁，油的品质降低，水滴侵入，油环卡住，转轴或轴衬表面的故障，在转轴颈与轴衬间的间隙缩小，轴承歪斜，轴颈压力过度及产生轴电流等所引起。

滚珠及滚柱轴承的过热，可能是由于润滑油不足或过多，转轴弯斜，转轴磨擦过大，润滑油内有杂质及外来物品以及钢珠损坏等所引起。

• 漏油及机内积油：是由于轴承内油量过多，轴承所有油质不良或粘度不对等所引起。也可能是由于轴承油槽内压力和轴承盖下压力不均匀所致。

• 电动机振动的厉害：机组的轴线没有对准，电动机在底板上的位置不正，转轴弯曲或轴颈振动，联轴器配合不良，转子皮带盘及联轴器平衡不良，轴颈与轴衬间的间隙过大，鼠笼转子断裂，转子铁心振动，底板不均匀的下沉，底板钢度不够，底板的振动周期与电动机（机组）的振动周期一样或接近，

皮带轮粗糙或皮带轮装置不正，传动机构工作不良及有碰撞现象等等。

- 转子偏心：可能是由于轴衬松掉、轴承位移，转子及定子铁心变形，转轴弯曲及转子平衡不良等所引起的。

2. 电气的故障：

启动时不正常：由于接线错误、线路断路、工作电压不对、负载力矩过高或静力矩过大和启动设备有故障等所引起。

- 电机过热：由于线路电压高于和低于额定值、过负荷、冷却空气量不足、电机环境温度过高、匝间短路及电动机不清洁等所引起。

- 绝缘损坏：可能由于工作电压过高，酸性、碱性、氯气等有腐蚀性气体的损坏、太脏、过热、机械碰伤、温度过高，在温度小于 0℃ 下保藏和水分侵入等所引起。

- 绝缘电阻：由于不清洁、湿度太大，因温度变化过甚，以致表面凝集水。

附件 1 轴承润滑油使用量和加油时间

机座号	极 数	油脂量 (g)	加油时间 (h)
180	2	20	4200
	4	20	7000
	6, 8	20	9000
200	2	25	3100
	4	25	6500
	6, 8	25	8500
225	2	25	3100
	4	30	6200
	6, 8	30	6200
250	2	30	2600
	4	35	6000
	6, 8	35	8000
280	2	35	2000
	4	40	5500
	6, 8	40	7500
315	2	30	2500
	4, 6, 8, 10	36	2500
355	2	36	2500
	4	47	2500
	6, 8, 10	47	2500

附件 2 机座号和适用轴承型号表

机座号	极 数	轴伸端	非轴伸端
63	2, 4	6201-2RZ	6201-2RZ
71	2, 4, 6	6202-2RZ	6202-2RZ
80	2, 4, 6, 8	6204-2RZ	6204-2RZ
90	2, 4, 6, 8	6205-2RZ	6205-2RZ
100	2, 4, 6, 8	6206-2RZ	6206-2RZ
112	2, 4, 6, 8	6206-2RZ	6206-2RZ
132	2, 4, 6, 8	6208-2RZ	6208-2RZ
160	2, 4, 6, 8	6309-2RZ	6309-2RZ
180	2, 4, 6, 8	6311-2RZ	6311-2RZ
200	2, 4, 6, 8	6312-2RZ	6312-2RZ
225	2, 4, 6, 8	6313-2RZ	6312-2RZ
250	2	6313	6313
	4, 6, 8	6314	6313
280	2	6314	6314
	4, 6, 8	6317	6314
315	2	6317	6317
	4, 6, 8, 10	NU319	6319
355	2	6319	6319
	4, 6, 8, 10	NU322	6322

注：电机用轴承型号以实物使用型号为准，如有变动，恕不另行通知。

We are truly grateful for your purchasing of Wannan Motors. Before using the motor, please scan the QR code to read the manual so as to use and maintain the motor in a right way.

YE4L Series Aluminum Casing Three Phase Asynchronous Motor is designed and manufactured according to level 2 of China national motor energy efficiency standard GB18613-2020. With aluminum frame, this series motor is light. This series motor can save energy in long time operation.

Model Instruction:

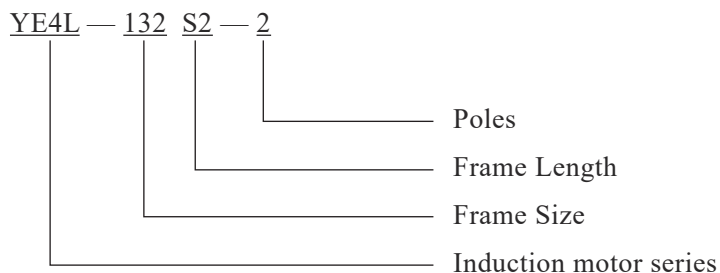

1. Application Circumstance

1.1 The altitude not exceeds 1000m above sea level.

1.2 The ambient temperature is neither higher than 40°C and nor lower than -15°C although it is always changing with season.

1.3 The average highest relative humidity of wet month is 90%, the lowest temperature in this month is not more than 25°C .

1.4 Motor can be started at full voltage or reduced voltage. Starting current is 3.3-8.0 times rated current if it starts with full voltage. As torque is proportional to voltage square, the torque will be reduced when the motor is started at reduced voltage. So if the static load is fairly large, the motor can be only started with rated voltage.

1.5 The motor can not be applied in the circumstance where contains inflammable gases, chemical corrosive gases and other harmful gases or steam (except for the special purpose motor).

1.6 Keep the motor clean and in good ventilation

1.7 There are two kinds of connections of the motor. Motor less than 4kw is of Y connection, 4kw and above are Δ connection. Ensure that all the terminals are connected as the diagram.

The right position is as follows:

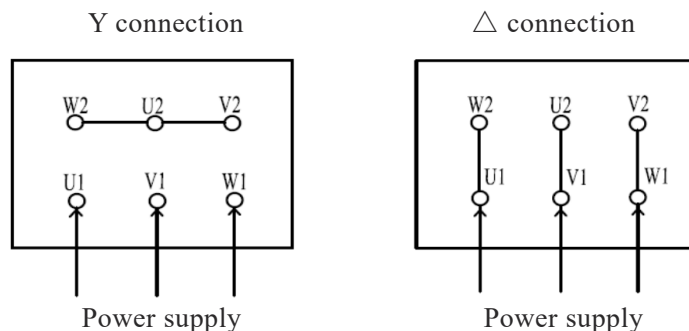

2. Installation & operation



Warning!

Be careful when handling motor !
Strong falling, bumping or shaking will damage bearing and other elements.
Make sure the eyebolt is tightened before lifting up the motor.

2.1 Inspection before installation

2.1.1 Check and make sure the appearance of the motor is in good order. Check and make sure the motor nameplate is consistent with the actual requirement.

2.1.2 Rotate the motor shaft gently and make sure it can rotate smoothly.

2.1.3 Ensure that all parts have been connected correctly and tightly.

2.1.4 Open the terminal box cover and measure the insulation resistance of the windings with 500v meg-ohmmeter, the value should not less than 5 MΩ.

Notice If you have any question during the inspection, please consult a professional technician or contact us.

2.2 Installation



Warning!

1. Voltage fluctuation of the supplied power should not exceed 95% ~ 105% of the rated voltage.
2. Connect the motor according to connection diagram strictly.
3. The motor should be grounded safely.
4. Remove the sleeve and key on the shaft end before power on, keep body and clothes far away from rotating parts of motor.
5. Stop the motor immediately if any abnormal problems occurs

2.2.1 Installation should be performed by professional.

2.2.2 Coupling, spur gear and belt pulley are allowed to be used for transmission.

2.2.3 The shaft center of the motor must keeps consisting with that of the driven machine.

2.2.4 If motor has mounting feet, ensure that the mounting face should be flat and solid.

2.2.4 Power line cable should neither too long nor too thin.

2.2.5 The core of the power line cable should be connected between the two gaskets, check and ensure there is no burr.

2.2.6 Check and ensure there is no damage on the cable when put through the cable entry of the terminal box, the cable should be fixed by a blanking plate and bow washer to prevent moving.

2.2.7 To fit different voltage different connection mode (by changing its connection straps) should be adopted (see the connection diagram on terminal box cover).

2.2.8 Motor will rotate clockwise viewed from driving shaft end if the terminal U,V,W is connected to power line phase sequence A, B, C. Otherwise the motor will rotate anti-clockwise.

Provided the revise rotation is need, the end user can change the any two of U, V, W sequence.

2.2.9 Ensure the internal & external grounding bolts have been safely grounded.

2.2.10 After checking all the connections, turn on power to run the motor with no-load for 30-40min, and then run the motor with load.

3. Operation & Maintenance



Warning!

1. Non-full phase operation is prohibited.
2. Repeated starting will cause overheat of motor, or even damage motor.(In particular, start with the load directly).
3. Prevent overload. Overload will cause overheating, and overheating will shorten the insulation life. As a result, it will reduce motor reliability.

3.1 Check and clean the motor periodically, make sure no dust cover the motor and do not inject water to clean the motor.

3.2 Bearing temperature should not exceed 95 °C (Thermometer method) during operation. The bearing should be inspected every 2500h operation at least. The bearing grease should be replaced immediately if the grease is found to be spoiled. Before that the waste grease at bearing external cover, storage box, grease discharging device including oil tube and oil cup should be cleaned up, and clean the bearing with machine oil. No.2 lubricating grease for small medium size motor is recommended. re-grease duration and grease mass see attachment 1, bearing type see attachment 2.

3.3 Turn the shaft by 180° with hand every 2 month for the motor which has been stored half year; the motor need to work for a period of time to make the lubrication grease equidistribution when the motor has been stored longer than half year.

3.4 No inner and outer bearing cover for H63-132 frame size motor. Disassemble the motor as the following order: firstly remove fan cover, and V-seal ring on the drive end, secondly remove the bolts on front end cover and rear end cover, and lastly take out the rotor together with the front end cover and cooling fan.

3.5 Motor must be dried before use if the motor has been affected with damp by means of drying in the oven or short-circuit current. The temperature should be increased gradually but not exceed 145°C if dried in the oven. And when the motor dried by short-circuit method, it should be connected as short circuit whose input current is 0.6-0.8 times rated current. However the short-circuit method is not suitable if the motor is heavily damped, since it may cause the electrolysis.

3.6 If the winding needs to be replaced, the original winding's type, dimensions, diameter and turns of coil should be recorded. Arbitrarily changing of winding will decrease the performance of the motor, and even to damage the motor.

3.7 Any maintenance or replacement of its components must be done by professional people.

3.8 The motor need to be periodically inspected according to its actual operation, overhaul at least once a year.

4. Failures & causes

Check motors frequently in order to remove the possible failure in advance. The common failures are as follows:

4.1 Mechanical fault:

4.1.1 Bearing overheating: lack of grease, dirty grease, low quality grease, water intrusion, oil ring stuck, surface fault of bushing, narrow distance between shaft and bushings, excessive pressure on shaft journal and axial current and so on.

4.1.2 Leakage of oil or grease: too much grease in bearing, grease of bad quality or incorrect viscosity, unbalanced pressure between bearing oil container and the bearing cover.

4.1.3 Strong vibration: inconsistent center line of the shaft between motor and the driven machine, incorrect mounting position on base plate, shaft bending, bad cooperation of coupling, unbalance of pulley or coupling, large space between shaft journal and bushing, broken rotor bar, vibration of stator core, uneven surface of base plate, inadequate rigidity of base plate, similar or same vibration cycle of the motor and the base plate, rough belt coupling, incorrect position of the belt coupling, poor operation of the transmission or the collision of the motor, etc.

4.1.4 Eccentric of rotor: loose bushing, bearing displacement, the deformation of rotor and stator, bend of the shaft and poor balance of the rotor.

4.2 Electrical Fault:

4.2.1 Abnormal starting: incorrect connection, open circuit, incorrect voltage, too high load torque and too high static torque, starting device failure and so on.

4.2.2 Motor overheating: much higher or lower than rated voltage, overload, lack of cooling air, too high ambient temperature, short circuit or uncleanness of the motor, etc.

4.2.3 Insulation damage: high working voltage, damage from corrosive gases like acid gas, alkaline gas and chlorine, too dirty, overheat, mechanical damage, excessive temperature, storage in environment whose temperature is lower than 0°C and water penetrating.

4.2.4 Poor insulation resistance: uncleanness, high humidity, surface condensation as result of sharp temperature variation, worn-out and aging of insulation material, etc.

Attachment 1 Lubrication Grease Content and Lifespan

Frame	Poles	Grease content (g)	Re-lubrication interval (h)
180	2	20	4200
	4	20	7000
	6,8	20	9000
200	2	25	3100
	4	25	6500
	6,8	25	8500
225	2	25	3100
	4	30	6200
	6,8	30	6200
250	2	30	2600
	4	35	6000
	6,8	35	8000
280	2	35	2000
	4	40	5500
	6,8	40	7500
315	2	30	2500
	4,6,8,10	36	2500
355	2	36	2500
	4	47	2500
	6,8,10	47	2500

Attachment 2 Frame and bearing size

Frame	Poles	DE	NDE
63	2,4	6201-2RZ	6201-2RZ
71	2,4,6	6202-2RZ	6202-2RZ
80	2,4,6,8	6204-2RZ	6204-2RZ
90	2,4,6,8	6205-2RZ	6205-2RZ
100	2,4,6,8	6206-2RZ	6206-2RZ
112	2,4,6,8	6206-2RZ	6206-2RZ
132	2,4,6,8	6208-2RZ	6208-2RZ
160	2,4,6,8	6309-2RZ	6309-2RZ
180	2,4,6,8	6311-2RZ	6311-2RZ
200	2,4,6,8	6312-2RZ	6312-2RZ
225	2,4,6,8	6313-2RZ	6312-2RZ
250	2	6313	6313
	4,6,8	6314	6313
280	2	6314	6314
	4,6,8	6317	6314
315	2	6317	6317
	4, 6,8,10	NU319	6319
355	2	6319	6319
	4, 6,8,10	NU322	6322

敬告用户：

请您按照本使用说明书的规定，正确地使用和储存电动机，我们将为您提供优质、快捷的服务。

在电动机使用过程中，您如有什么疑惑请与我们联系，我们将及时给予您满意的解答；您有什么良好的建议请向我们提出，以便我们改进，为您提供优质、快捷的服务。

安徽皖南电机股份有限公司对本使用说明书保留最终解释权。

请勿在未事先获得安徽皖南电机股份有限公司书面许可的情况下向第三方复制、公布或者使用本使用说明书内容。

Dear user,

Please use and store the motor right following the instruction of the manual. We will make our effort to provide you with high-quality and prompt service. Contact us if you had any questions in application, and we will offer you timely and effective resolution; let us know if you had any advices or suggestions, with which we can improve ourselves and make service better. Anhui Wannan Motor Co., Ltd. reserves the right of final interpretation of the user manual. No copy, disclosing or using of the content of this user manual to third parties prior to written permission from Anhui Wannan Motor Co., Ltd.

安徽皖南电机股份有限公司

Anhui Wannan Electric Machine Co.,Ltd

地址：安徽省泾县泾川镇南华路 86 号

Address: No.86 Nanhua Road Jingxian County Anhui Province P.R.C

销售处 **Sales department:** 400-111-0563 0563-5031908 5031988

客户服务中心 **Customer service center:** 0563-5031953

企业管理处 **Enterprises management department:** 0563-5031954

质量检验处 **Quality inspection department:** 0563-5031910 5031985

传真 **Fax:** (0563) 5029999 5023698

网址 **Website:** <http://www.wnmotor.com>

E-mail: wndjc@wnmotor.com

邮编 **Postal code:** 242500

本说明书内容如有变动，恕不另行通知。

Content in the manual may be changed without prior notice.